Operating Manual



• COCOON AERIS •

SAVE THESE INSTRUCTIONS

Cocoon Fires is very safety conscious and we have taken every care in designing, manufacturing and assembling your Cocoon Fires Burner to ensure it operates effectively, efficiently and safely. Please exercise care when using this product and follow the instructions below. Cocoon Fires cannot be held responsible for any damage or injury caused if the information supplied in this manual are not adhered to.

WARNING - IMPORTANT SAFEGUARDS

Read all instructions and warnings before installation and use.

- NEVER LEAVE THE APPLIANCE UNATTENDED DURING OPERATION OR WHEN A FLAME IS PRESENT.
- DO NOT IGNITE THE COMBUSTION CHAMBER WHEN IT IS IN A HOT STATE.
- THIS PRODUCT IS TO BE USED ONLY IN ROOMS ACCORDING TO THE MANUAL.
- KEEP AWAY FROM CHILDREN.
- STORAGE OF YOUR FUEL IS TO BE DONE IN ACCORDANCE WITH NATIONAL AND/OR REGIONAL REGULATIONS.
- THIS PRODUCT IS FOR DECORATIVE AND DOMESTIC USE ONLY.
- NOT SUITABLE FOR CONTINUOUS OPERATION.
- OPERATION OF SEVERAL APPLIANCE IN ONE ROOM IS ONLY ALLOWED IF THE POWER OUTPUT IS EQUAL TO OR LOWER THAN 4,5 kW/h AND ADDITIONAL VENTILATION IS REQUIRED IF THIS IS EXCEEDED.
- DO NOT OVERFILL THE BURNER'S INTENDED CAPACITY.
- OVERFILLING WILL CAUSE THE APPARATUS TO BURN AT HIGHER TEMPERATURE RATES RESULTING IN THE APPARATUS BEING DIFFICULT TO TURN OFF.
- DO NOT INSTALL INTO AN AREA WHERE THERE IS A DRAFT WHICH CAN AFFECT THE FLAME.
- USE ONLY THE FUEL FOR WHICH THE COMBUSTION CHAMBER IS INTENDED.
- DO NOT TOUCH THE EXTERIOR OF THE CHIMENEA DURING OR AFTER BURNING.
- PARTS OF THIS CHIMENEA AND ESPECIALLY THE COMBUSTION CHAMBER CAN REACH HIGH TEMPERATURES DURING OPERATION.
- DO NOT COVER NOR MOVE THE COMBUSTION CHAMBER OR CHIMENEA DURING OPERATION.
- DO NOT HAVE COMBUSTIBLE OBJECTS IN CLOSE PROXIMITY TO THE CHIMENEA.
- NEVER POSITION THE BURNER WITHIN RANGE OF COMBUSTIBLE ITEMS THAT CAN BE MOVED/BUMPED BY ACCIDENT OR BLOWN BY THE WIND. e.g CURTAINS, PAPERS & BLANKETS
- ONLY USE THE CHIMENEA IN AREAS WITH GOOD VENTILATION.
- DRAFT AREAS WILL CAUSE THE APPARATUS TO BURN AT HIGHER TEMPERATURE RATES RESULTING IN THE APPARATUS BEING DIFFICULT TO TURN OFF, THEREFORE THE APPARATUS SHOULD NOT BE USED IN A DRAFT AREA.
- DO NOT COVER THE CHIMENEA VENT WITH ANY DECORATIVE ITEMS WHETHER THEY ARE COMBUSTIBLE OR NON-COMBUSTIBLE, INCLUDING BUT NOT LIMITED TO ARTIFICIAL LOGS, STONES, PEBBLES, GLASS BEADS etc.
- THIS APPARATUS HAS NOT BEEN TESTED WITH AN UNVENTED GAS LOG SET, TO REDUCE THE RISK OF FIRE OR INJURY, DO NOT INSTALL AN UNVENTED GAS LOG SET INTO THIS APPLIANCE.
- WARNING: FILLING AN ALCOHOL FUELLED DEVICE WHILE LIT HAS CAUSED SEVERE BURNS AND DEATHS. YOU MUST REMOVE THE FUEL TANK FROM THE DEVICE BEFORE REFILLING. WHEN REFILLING ONLY USE CONTAINER WITH A FLAME ARRESTER. WHEN REFILLING FIRST CHECK THE FLAME IS EXTINGUISHED AND THAT THE DEVICE IS COOL.



PARTS NAMES AND DESCRIPTIONS

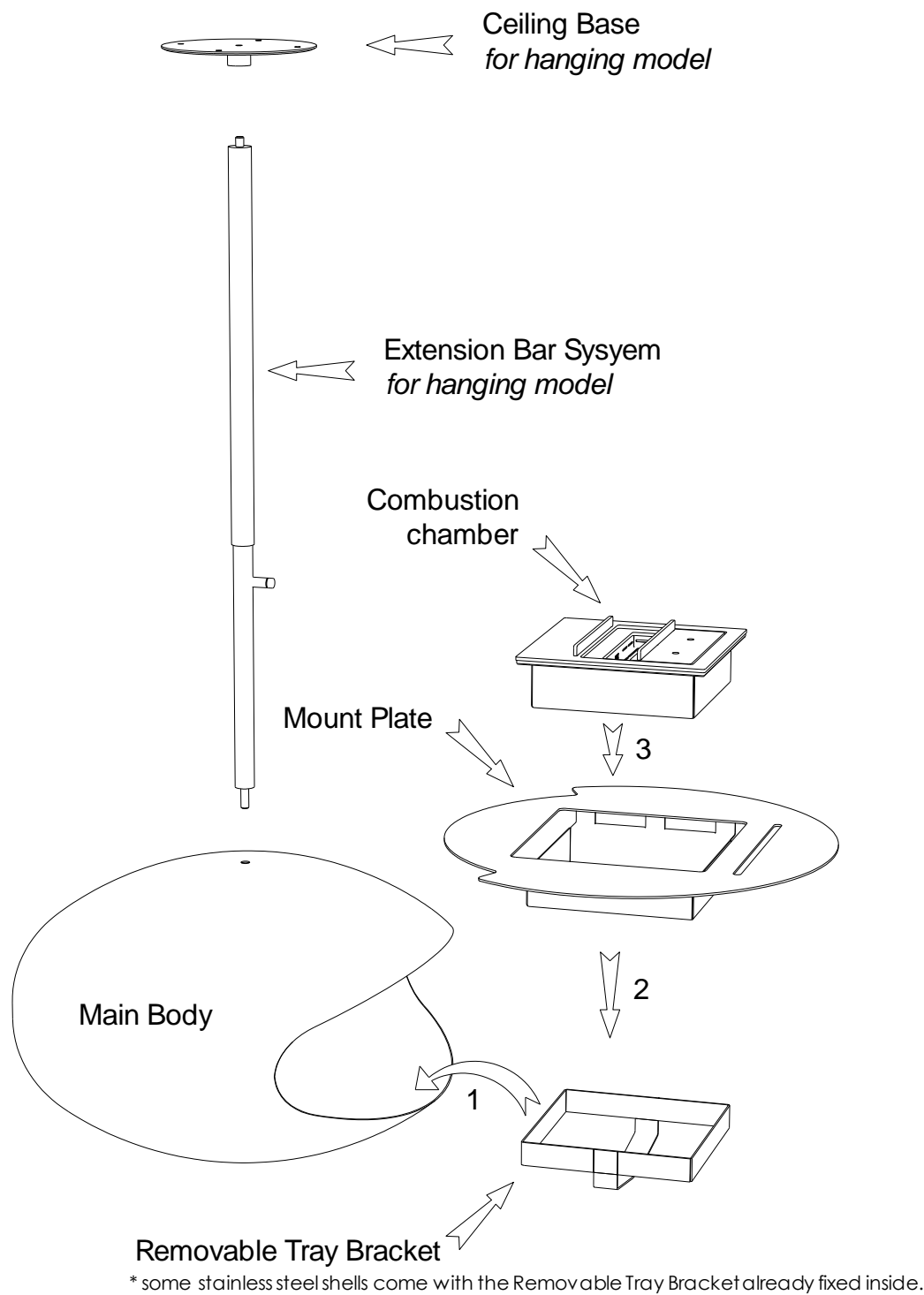

For hanging model:

- 1 security hex nut to secure extension bar to ceiling base.
- 1 security hex nut to secure extension bar to main body.

Optional for hanging model:

Extension bars are available to extend length of extension bar system in 50 cm (19,6 in) and 100 cm (39,2 in).

PARTS NAMES AND DESCRIPTIONS

Main Body or Chimenea Dimensions:

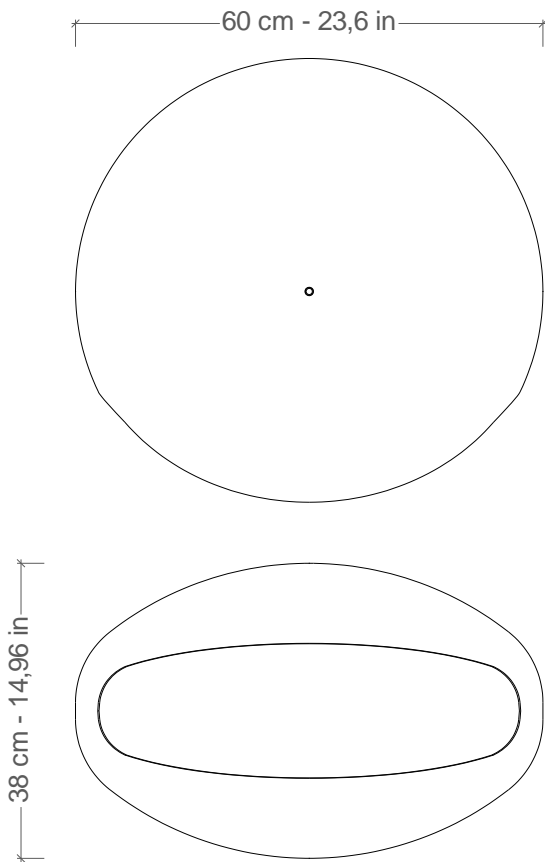

Additional Parts & Accessories:

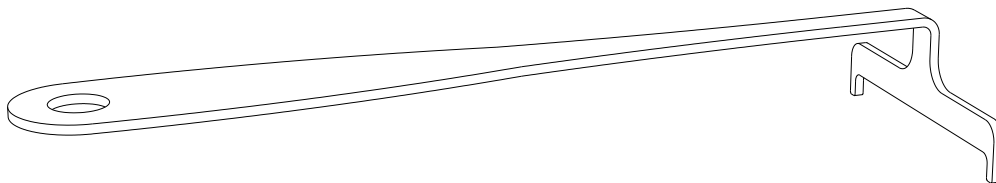

The **Sliding Lid Handle** is used to adjust the intensity of the flame by sliding the *Sliding Lid* backwards and forwards, and also to extinguish the flame by sliding the *Sliding Lid* into the closed position.

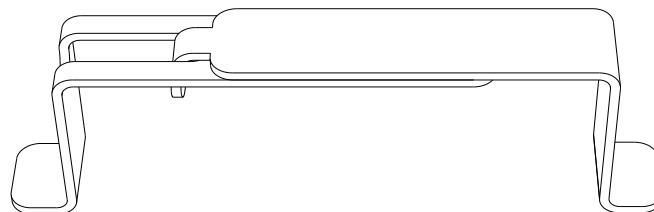

The **Lifting Handles** are supplied in order to carry the *Combustion Chamber* should it need to be moved when it is too hot to touch, they should never be used while there is still a flame in the *Combustion Chamber*, see next page for how to operate.

ADDITIONAL PARTS NAMES AND DESCRIPTIONS

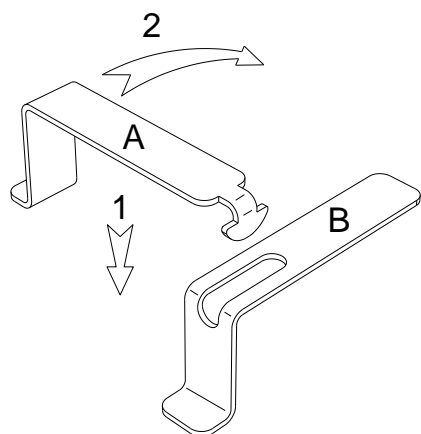

The *Lifting Handle* is used to take the *Combustion Chamber* in and out of the *Mount Plate* inside the *Main Body* for filling and cleaning. Step 1 is to join Part A and Part B as shown to the left. Once you have placed the tag of Part A into the slot of Part B, then twist it 90 degrees to lock them as one handle.

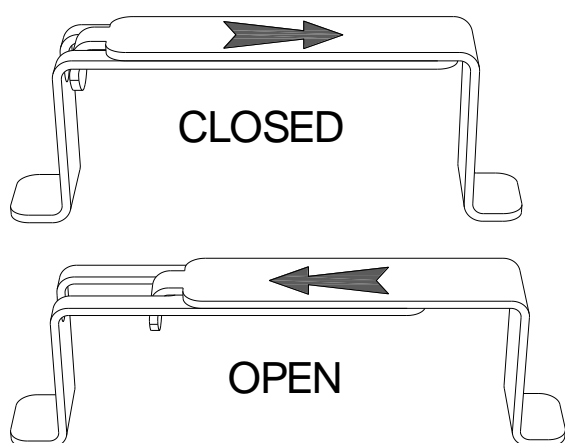

Once both parts of the handle are clipped together as shown on the previous image, the handle can be slid into an open or a closed position as shown on the left. To use the handle correctly to lift the *Combustion Chamber* in and out of the *Mount Plate* inside the *Main Body*, follow the instructions below. It is very important that when handling the *Combustion Chamber* with the *Lifting Handles*, that the combustion chamber be kept as level as possible to avoid spilling of fuel.

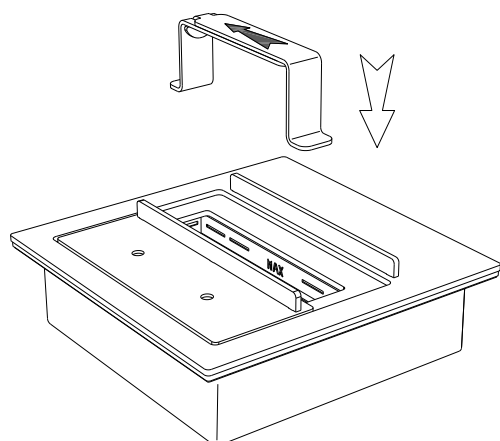

With the handle in the closed position, lower the flat tabs at the bottom of the *Lifting Handle* into the *Burner Vent* opening of the *Combustion Chamber*.

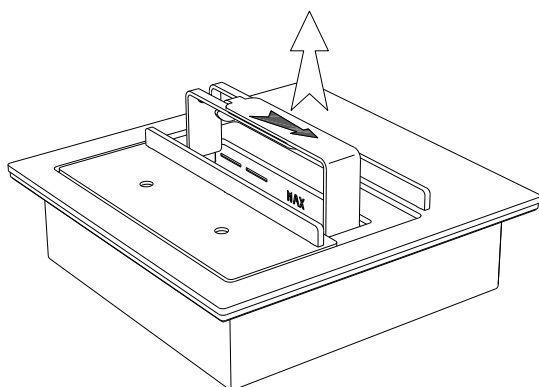

When the flat ends of the *Lifting Handles* are all the way inside the *Combustion Chamber*, slide the handle into the open position as far as it will go. Grip the handles Parts A and Part B firmly with one hand in the fully open position, then lift and insert the *Combustion Chamber* inside the *Mount Plate*.

Combustion Chamber:

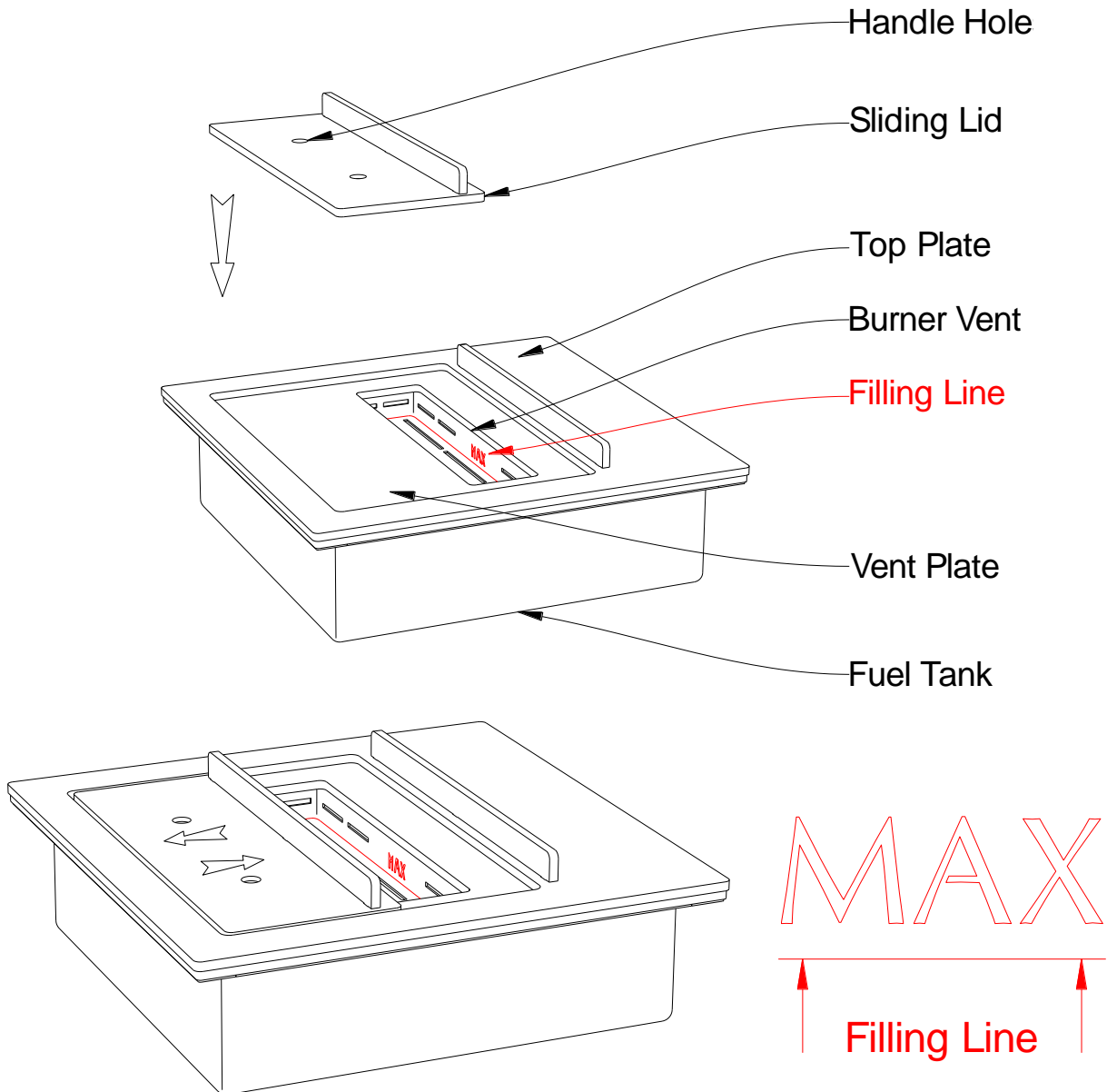

PROCEDURE IF BURNER IS OVERFILLED:

In case of accidental overfilling of the *Fuel Tank*, follow these steps:

- **NEVER** ignite the *Combustion Chamber* if it is filled past the "**MAX**" filling line shown above. Remove the *Combustion Chamber* from the *Chimenea*, using the *lifting Handles*.
- Empty the excess fuel into a container, kitchen sink or toilet bowl.
- Wipe off all excess fuel that may have dripped on the outside of the *Combustion Chamber* during emptying and allow any residual fuel to evaporate. Leave for 1 hour.
- Place the *Combustion Chamber* back into *Chimenea*.
- Ignite the *Combustion Chamber* only once all residual fuel outside the *Combustion Chamber* has completely evaporated and the container used to fill it has been sealed and moved to a safe distance from the *Combustion Chamber*.

SAFETY & CLEARANCE

WARNING:

- Aim opening away from flammable objects or surfaces.
- Ceiling mounting surface must be load bearing and be able to support a minimum mass of 150 kg / 330 lb or more. Total product weight is 23 kg / 50,7 lb

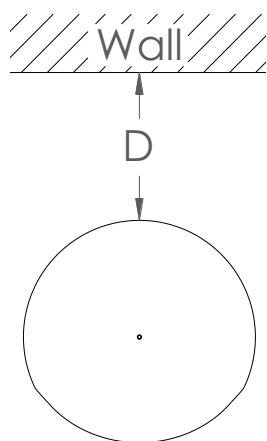
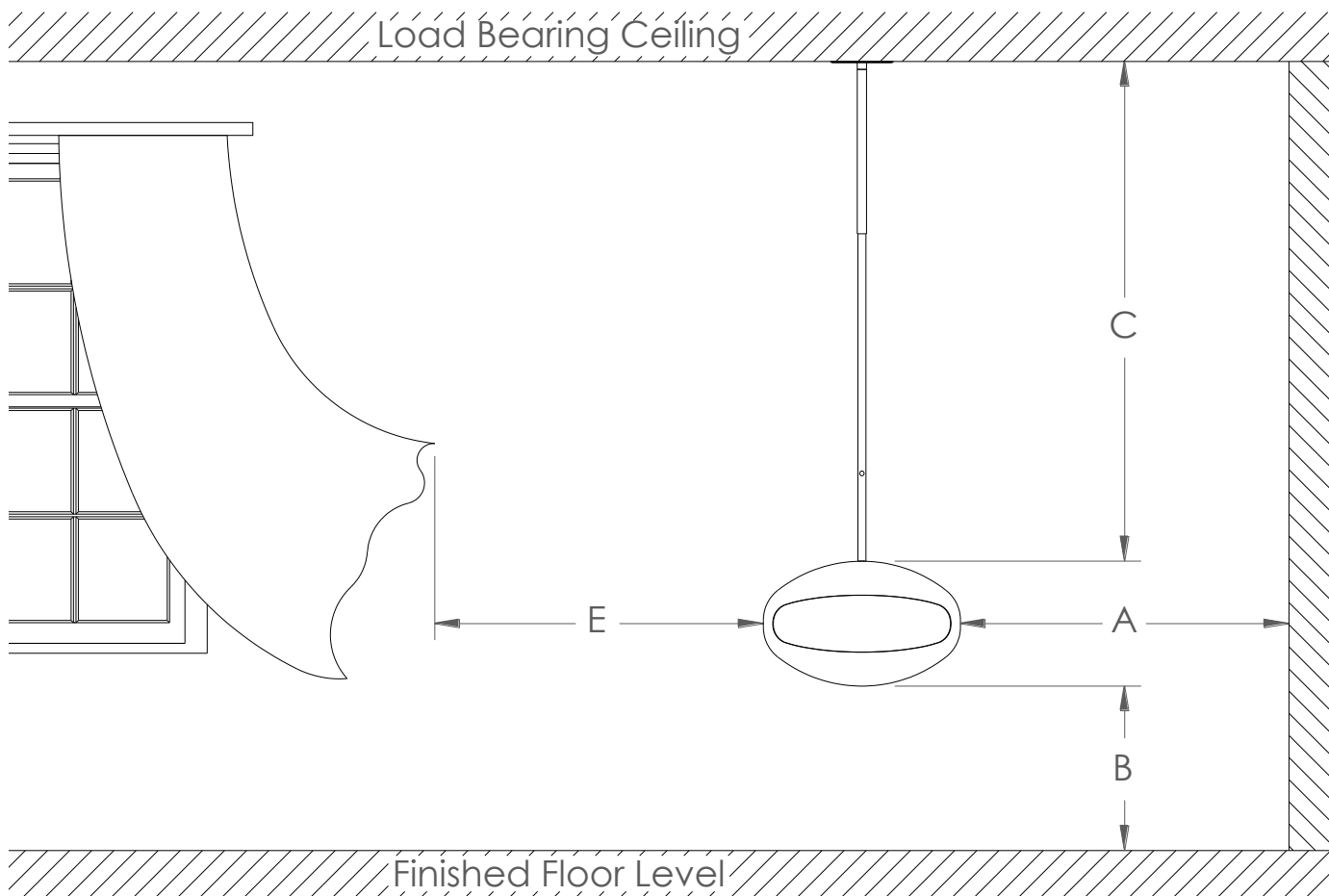

MINIMUM DISTANCES:

A - 10,2 cm - 4 in - min

B - 38,1 cm - 15 in - min

C - 102 cm - 40 in - min

D - 3,8 cm - 1,5 in - min to **non-combustible** wall

E - 102cm - 40 in - min distance to **combustible** items

Chiminea ↑ Opening

NOTE: In all cases, the *Chimenea* must:

- be installed onto load bearing material ONLY;
- be installed in low traffic areas to avoid injury to persons moving around and to avoid the *Chimenea* being bumped which may cause fuel to spill.
- have all gas connections or pipelines near *Chimenea* installation must be disconnected and made safe by an appropriately qualified professional prior to installation;
- be installed onto a load bearing, level and secure position before filling, lighting and operating;
- be installed in a position that limits relocation requirements to eliminate the risk of accidents caused by fuel spillage. This *Chimenea* is designed to be relocated but *Combustion Chamber* must be removed from the *Main Body* before relocating to avoid fuel spillage;
- NOT be installed directly beside or near wallpaper, laminate, veneer or any surface that has not been fire rated and considered combustible.
- A minimum of 102 cm radius to any combustible material.
- NOT be within the reach of any objects that are not fixed in position and can be moved by the wind or bumped over easily i.e. curtains, blankets, newspapers etc.

KEEP HANDY A CLASS B FIRE EXTINGUISHER

Class B fire extinguishers are used to put out fires that are fueled by combustible liquids. Class B extinguishers quell the flames by expelling a dry chemical powder or foam with a nitrogen propellant. The specific chemical can vary depending on the maker or model.

USE CORRECT FUEL – COMMERCIAL NAMES

Australia, India, New Zealand, South Africa: Methylated Spirits, **France:** Bio-Ethanol, **Germany:** Spiritus – Brenn Spiritus – Methyl Alcohol, **Holland/Netherlands/Belgium:** Spiritus – Brand Spiritus, **Italy:** Alcool Denaturato – Spirito De Brucaire, **Japan:** Nen-ryo yoh, **Scandinavia:** T-spirit – Tod Spirit – denaturoito sprii – Sinol – Marinol, **Spain:** Alcohol Metilico – Alcohol de Quemar, **Switzerland:** Brennsprit, **Turkey:** Ispirto, **UK:** Meths, **USA & Canada:** Denatured Alcohol – Bio-Ethanol

FUEL IS TO BE STORED IN A FIRE SAFE AREA AND IS TO BE DONE IN ACCORDANCE WITH NATIONAL AND/OR REGIONAL REGULATIONS.

WARNING:

In a house of typical construction, that is, one that is not of unusually tight construction due to heavy insulation and tight seals against air infiltration, an adequate supply of air for combustion and ventilation is provided through infiltration. However, if the unvented decorative appliance is used in a small room where less than 200 cubic feet (5,7 m³) of air space is provided for each 1000 Btu per hour of unvented decorative appliance rating (considering the maximum burner adjustment), the door(s) to adjacent room(s) should be kept open or a window to the outside should be opened at least 1 inch (2,4 cm) to guard against potential build-up of indoor air pollution. Do not use the unvented decorative appliance in a bathroom, a room(s) where sleeping accommodation is provided or any other small room(s).

HANGING MODEL INSTALLATION & ADJUSTMENTS

NOTE: may only be fitted onto a load bearing surface that can handle 150kg or more. Plastic fixings may not be used otherwise they could melt, all fixings must be metal.



1 - Mark and drill 4 holes in the ceiling and insert the corresponding dowels into the holes (Dowels are not provided).



2 - Fix the base on the ceiling by screwing it into the dowels (Fixing screws are not provided).

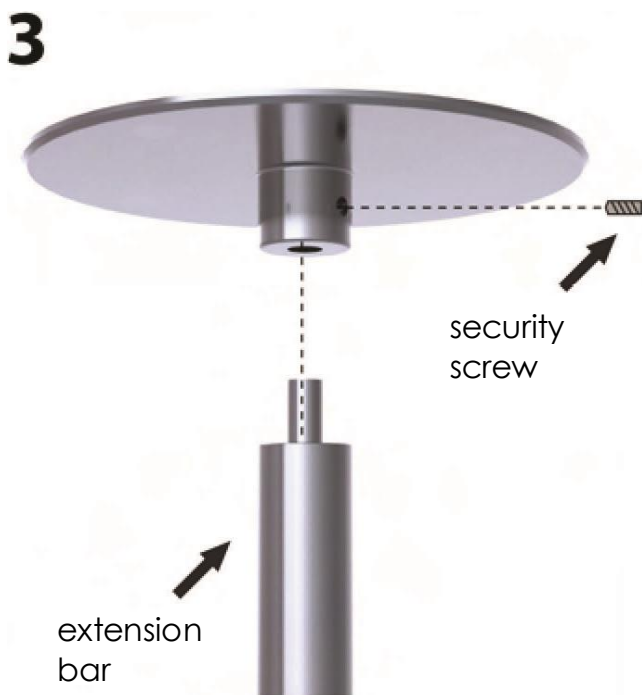

3 - Screw in extension bar system into base and secure it with the side security screw.

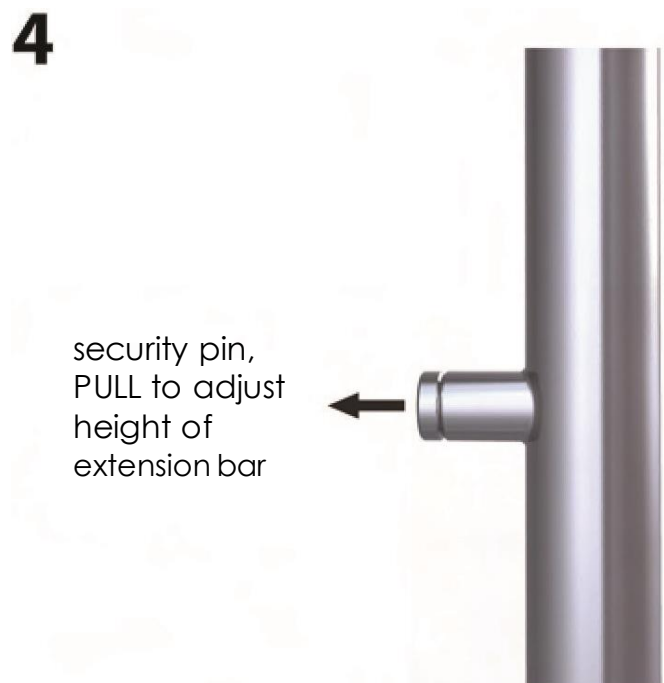

Adjust the height of the extension bar system by pulling the security pin on the side and raising or lowering the bar.

HANGING MODEL INSTALLATION & ADJUSTMENTS

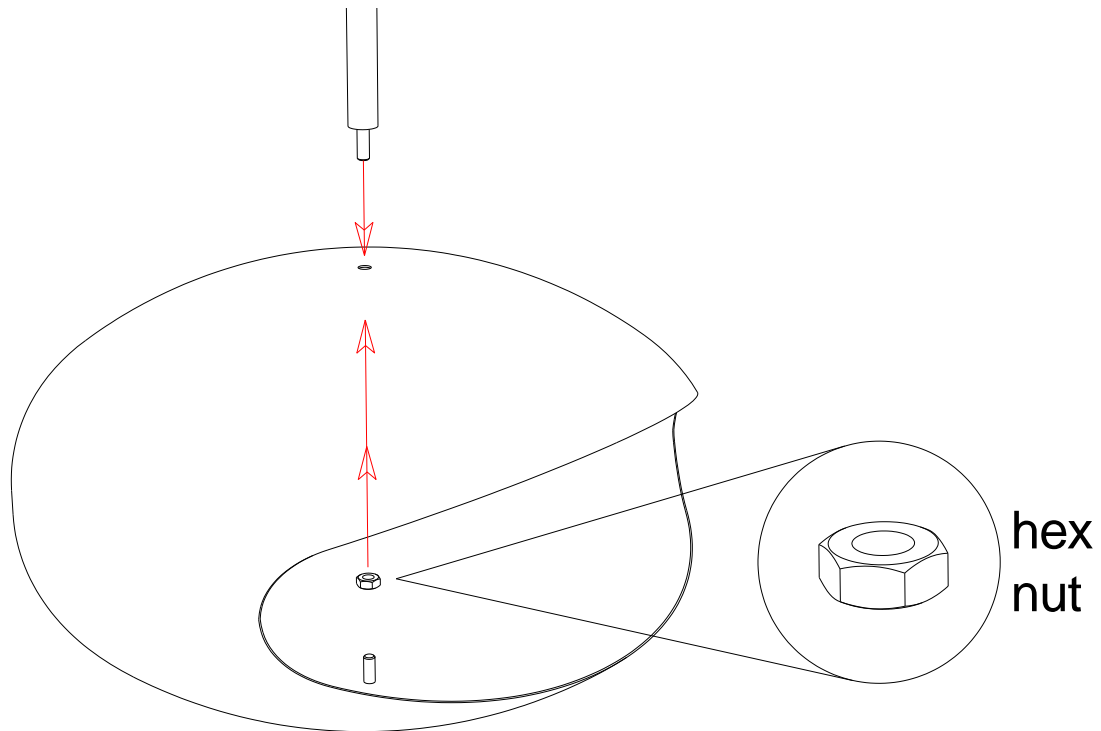

Position *Main Body* into hanging bar and secure from inside with wing type nut.

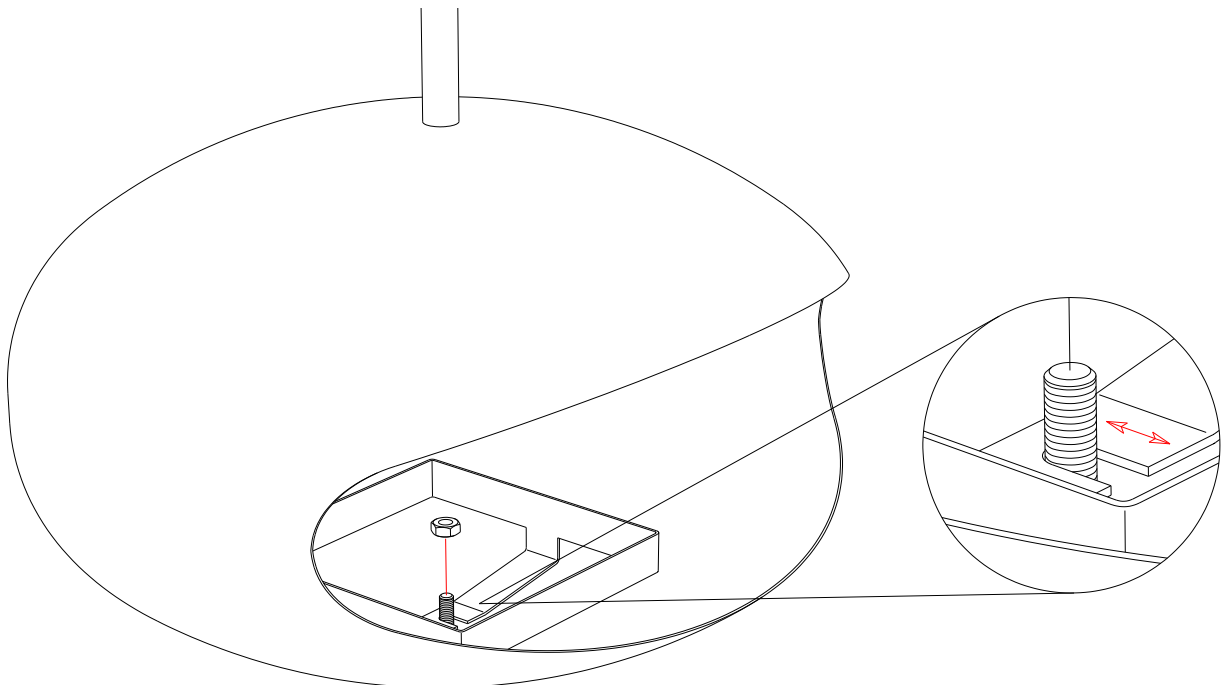

Position the *Movable Tray Bracket* over the threaded stud at the base of the *Main Body* and adjust according to the instructions on the following page before securing with hex nut.
NOTE: adjustment instructions on the following page are critical to proper functioning of the Combustion Chamber.

HANGING MODEL INSTALLATION & ADJUSTMENTS

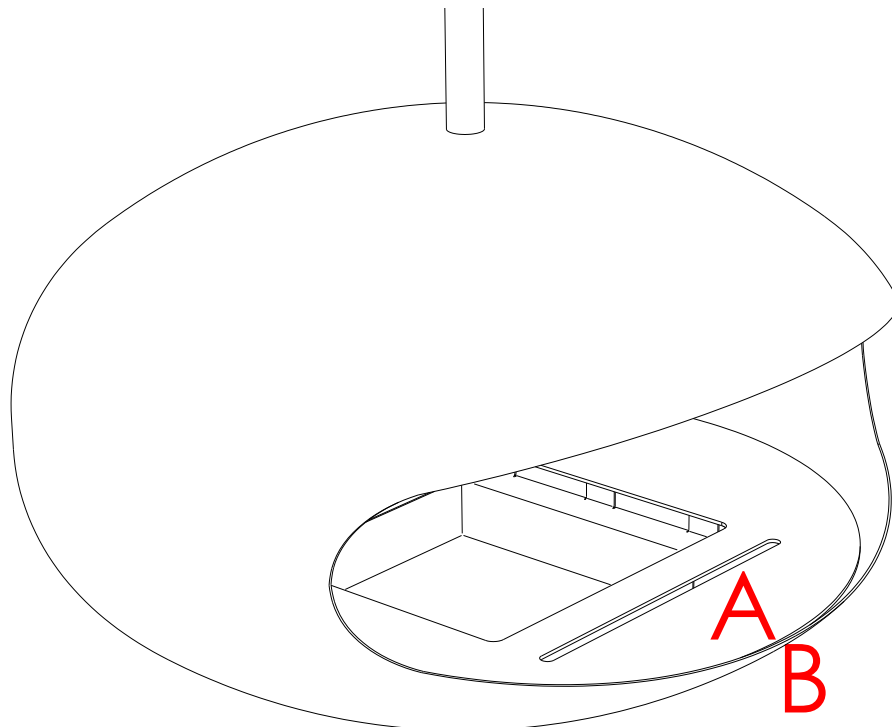
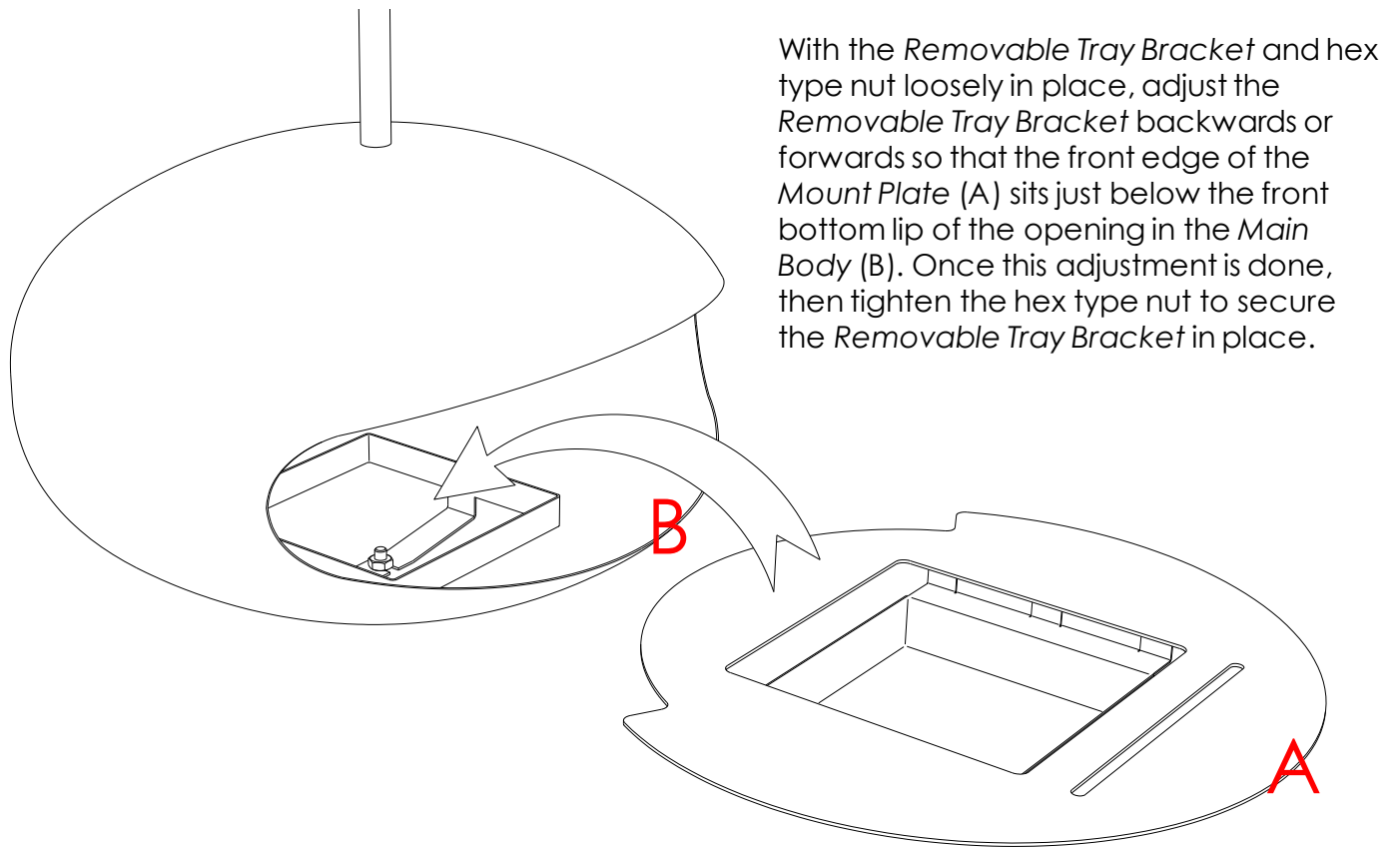

NOTE: adjustment instructions on the following page showing relative positions of (A) and (B) shown above are critical to the airflow inside the *Main Body* and therefore critical to the proper functioning of the *Combustion Chamber*.

HANGING MODEL INSTALLATION & ADJUSTMENTS

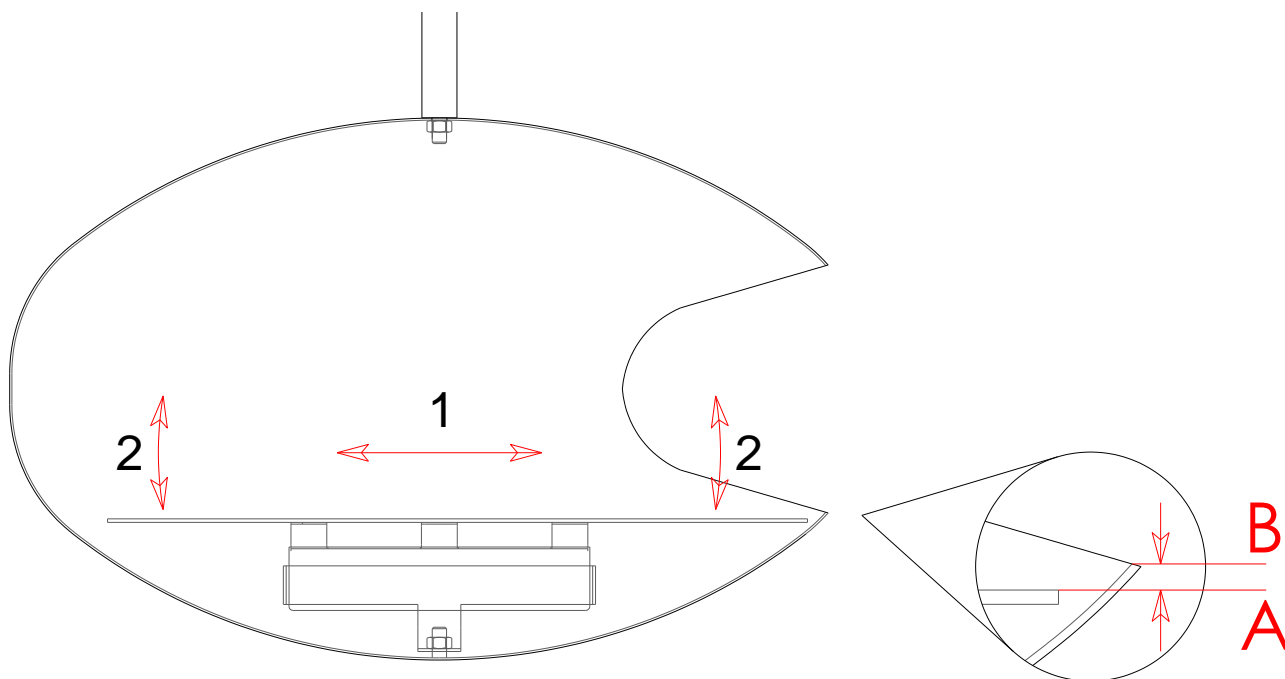

By finely adjusting the *Removable Tray Bracket* backward and forward (1) allows for the necessary adjustment in height (2) of the *Mount Plate*.

NOTE: the front edge of the *Mount Plate* (A) must be just below the front bottom lip of the opening in the *Main Body* (B).

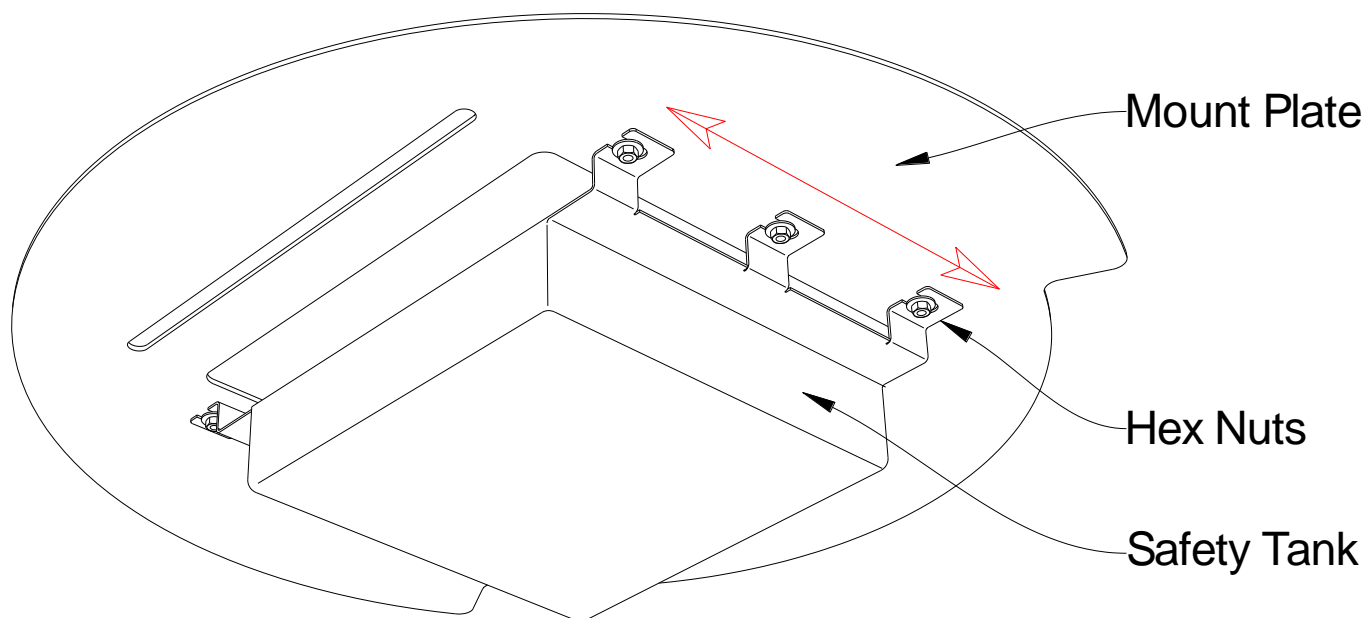

Further adjustment to the position of the *Mount Plate* can be achieved by loosening the 6 hex nuts below the *Mount Plate* and sliding the *Safety Tank* front to back slightly. Always make sure that the *Safety Tank* below the *Mount plate* is properly secured after this adjustment.

NOTE: every time you fill the *Combustion Chamber*, this *safety tank* should be checked for residual fuel to ensure that there is no fuel leaking from the *Fuel Tank*.

HANGING MODEL INSTALLATION & ADJUSTMENTS

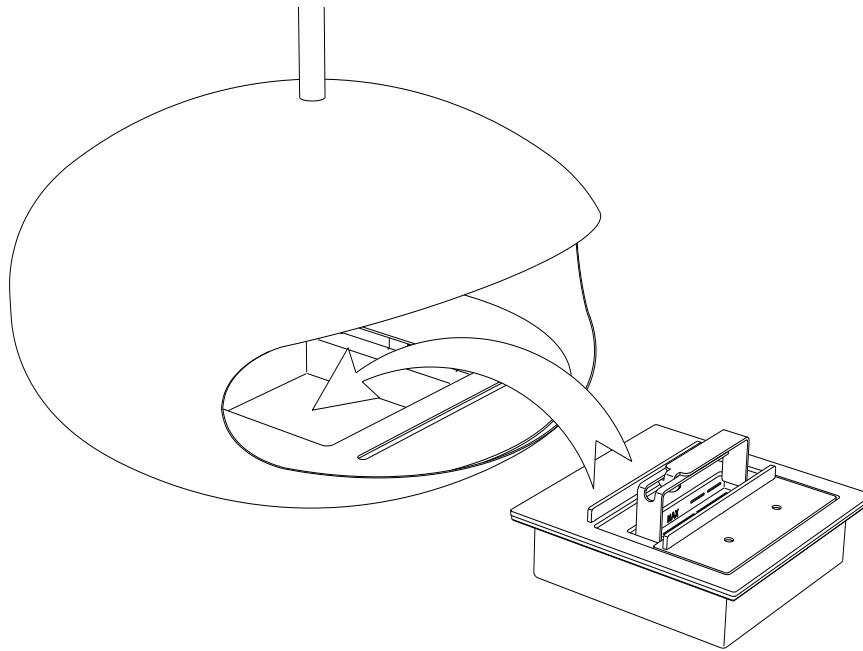

With the *Mount Plate* in the correct position and secured in place with the hex nut, the *Combustion Chamber* can now be placed inside and taken off the *Mount Plate* opening using the *Lifting Handles* supplied as shown on the previous pages.

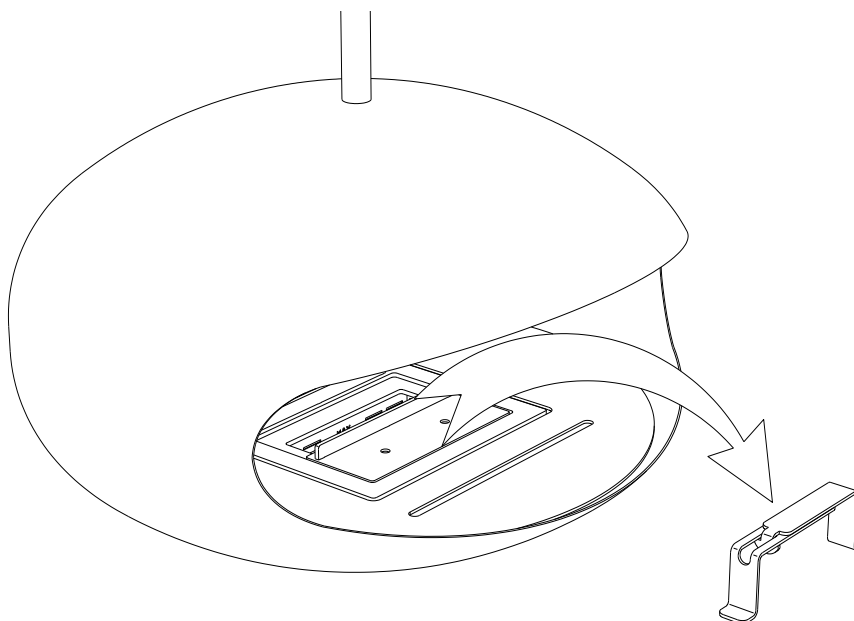

Your Cocoon Burner is now ready to use, follow the steps on the following pages to correctly and safely fill, ignite, adjust, shut off and refill the Combustion Chamber. Always make sure the Lifting Handles are removed from the Combustion Chamber as shown above when it is not in use otherwise these parts will become too hot to touch and may cause injury.

TROUBLESHOOTING AND OPERATIONAL TIPS

- The **first fill** will take longer as the material inside the *Fuel Tank* will absorb the fuel. Subsequent filling should be quicker. Take care to not fill the *Combustion Chamber* at a faster rate than what the material inside can absorb the fuel.
- If the fire **does not extinguish** the first time by closing the *Sliding Lid* follow these steps and repeat if necessary.
 - Check that the surface below the *Sliding Lid* is clean and free from obstruction.
 - Using the *Sliding Lid Handle*, apply downward force and in one quick motion move the *Sliding Lid* towards the closed position. If the flame is still visible repeat this step as a double motion still applying strong downward force in quick succession.
- **Never blow on the flame** whilst the *Sliding Lid* is in an open position.
- If after some time you find the *Sliding Lid* has **become 'sticky'** when attempting to move it then remove the *Sliding Lid* from its housing and rub the underside using the green side of a Scotch Bright scouring pad. Take care to only scrub in the direction of the brushing lines of the stainless steel.
- Make sure you keep your *Combustion Chamber* clean especially the surface that the *Sliding Lid* slides on and ensure that any excess fuel on the surface of the *Combustion Chamber* is wiped off before use.
 - **MAKE SURE THAT ALL PARTS HAVE COOLED OFF COMPLETELY BEFORE CLEANING:**
 - To clean dust, wipe with a dry cloth or sponge.
 - To clean stainless steel parts, use bioethanol or Acetone.
 - Make sure the *Sliding Lid* for the *Combustion Chamber* slides correctly and fully after cleaning and that any excess cleaning product has been wiped off completely.

CAUTION

- **Make sure you have read and understood this manual before using this product.**
- **Do not overfill or spill fuel when refilling.**
- **If fuel is spilled, wipe with a dry cloth and allow the rest to evaporate before introducing a flame to the combustion chamber.**
- **If the burner is accidentally overfilled, follow the steps given in these next pages.**
- **To refill, wait until the burner is at the room temperature after the flame has been turned off.**
NOTE: the flame may not be visible to the naked eye in daylight.
- **Never refill over or near an open flame.**
- **Remove all plastic & packaging before using the burner.**

OPERATING THE COCOON BURNER

NOTE: Overfilling will cause the apparatus to burn at higher temperature rates resulting in the apparatus being difficult to turn off.

IMPORTANT: Please ensure the burner is removed from the *Main Body* before filling with fuel.

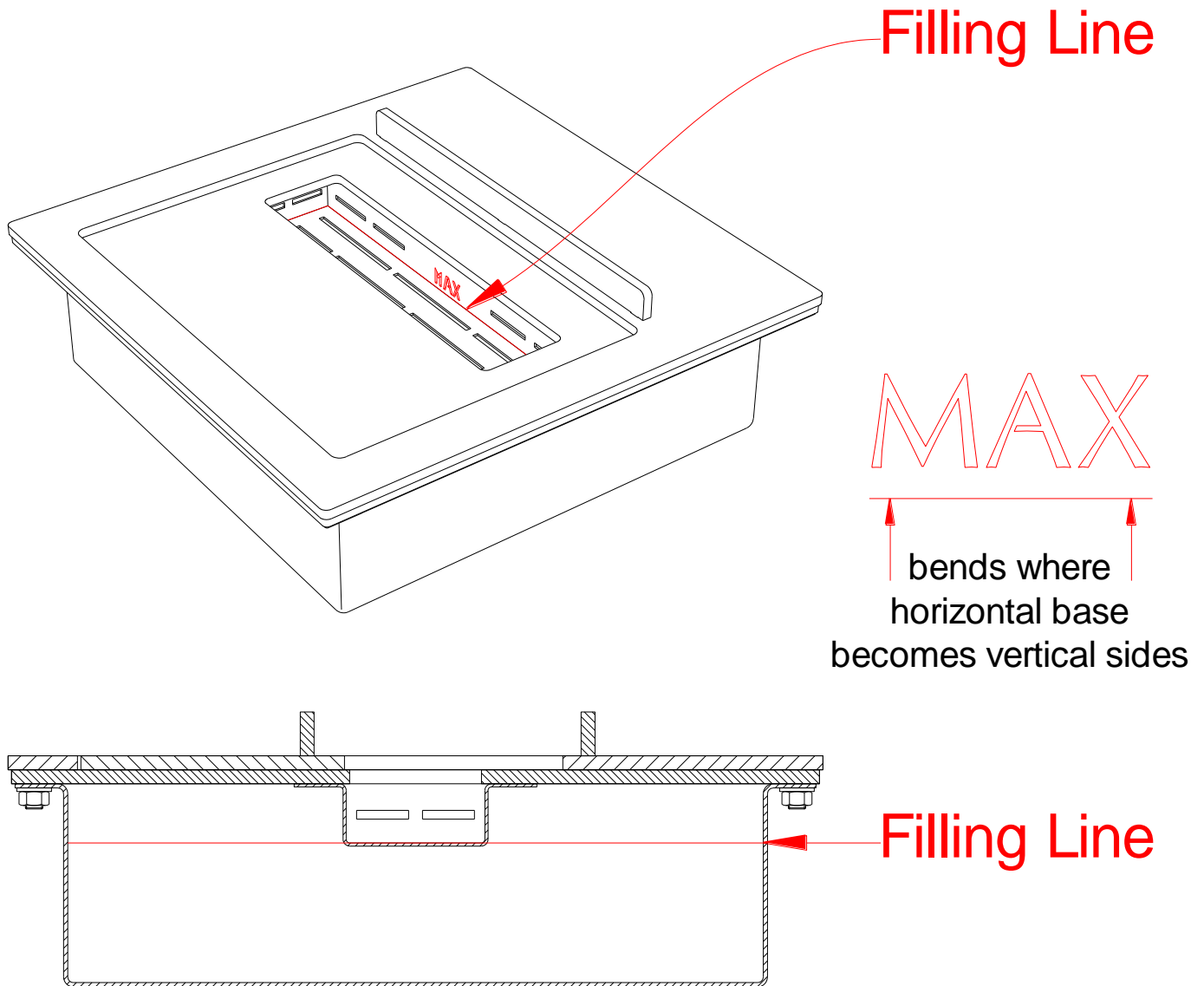

To fill the *Combustion Chamber*, remove it from the *Main Body* using the *Lifting Handles* and pour fuel inside the *Vent Opening* being careful not to spill. Fill up to the fill line as indicated in red with no more than 1.5L of fuel (3-5 hrs burning time). After filling is done, wipe away any spilled or excess fuel before returning the *Combustion Chamber* to the *Mount Plate* opening.

NOTE: after filling the combustion chamber, place the fuel dispenser used to fill it with and any other forms of fuel or combustible items at a safe distance away before proceeding to start the fireplace.

IGNITING THE COMBUSTION CHAMBER

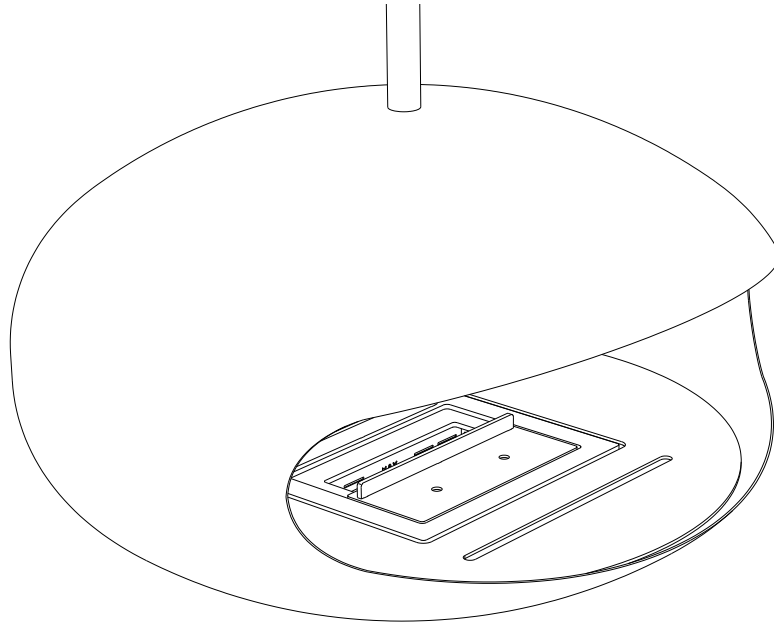

Once all spilled or residual fuel has been wiped clean, and all other forms of fuel have been sealed and moved to a safe distance from the *Combustion Chamber*, and the *Combustion Chamber* has been placed back inside the *Chimenea* as indicated above, it is safe to consider igniting the *Combustion Chamber*.

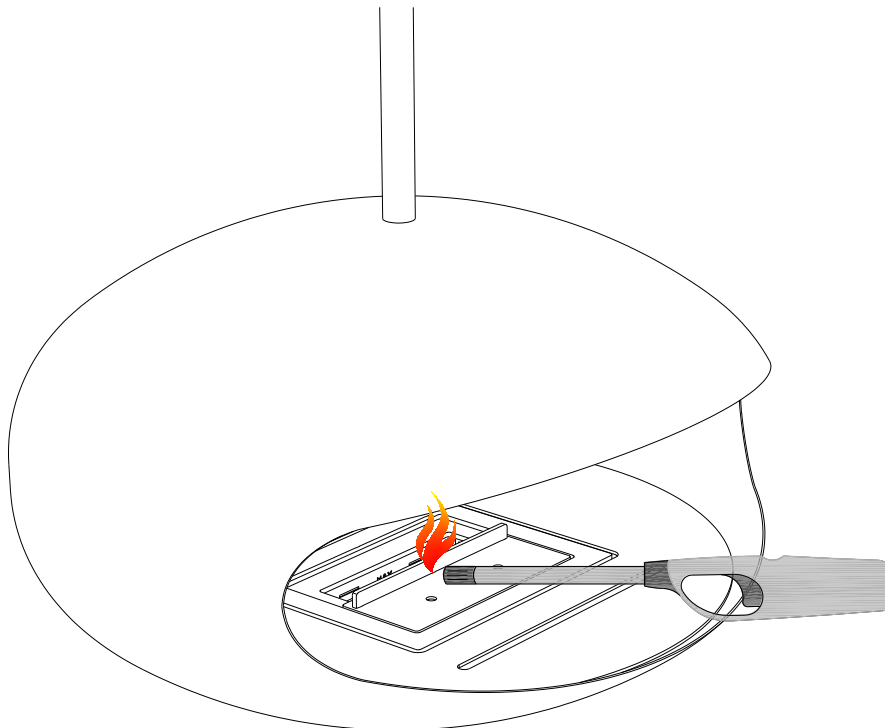

Using a long arm fire lighter and standing at a safe distance from the *Combustion Chamber* carefully introduce a flame as indicated above to ignite the *Combustion Chamber*. Always make sure there is a Class B fire extinguisher close at hand when igniting the *Combustion Chamber*.

REGULATING AND EXTINGUISHING THE FLAME

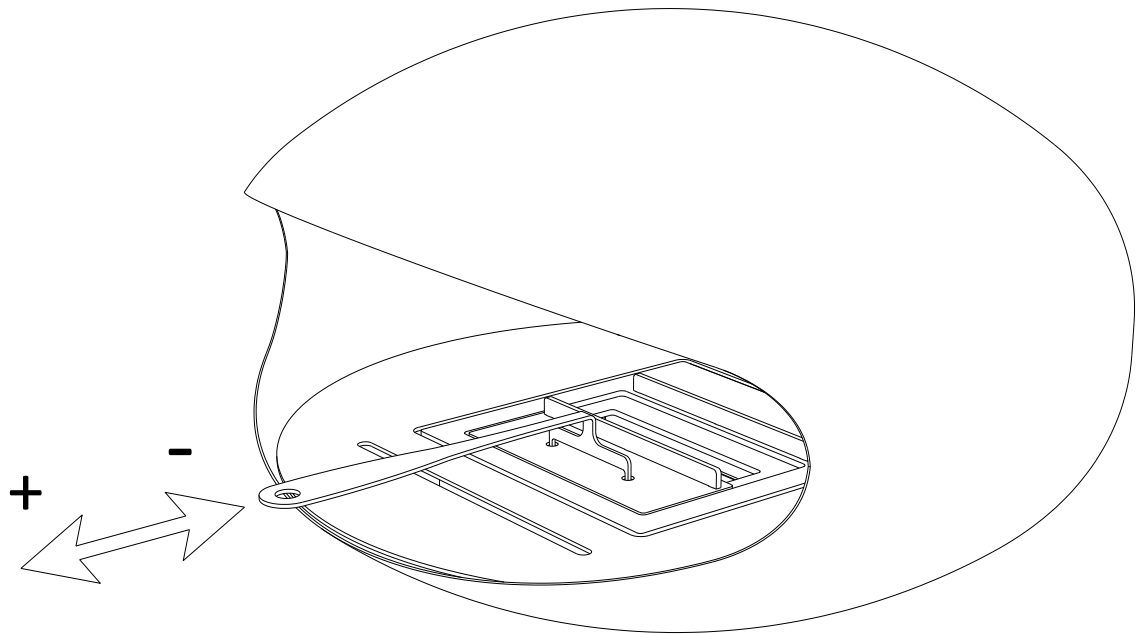

To regulate the flame, insert the tips of the *Sliding Lid Handle* into the holes of the *Sliding Lid* of the *Combustion Chamber* and slide backwards or forwards to regulate the flame size.

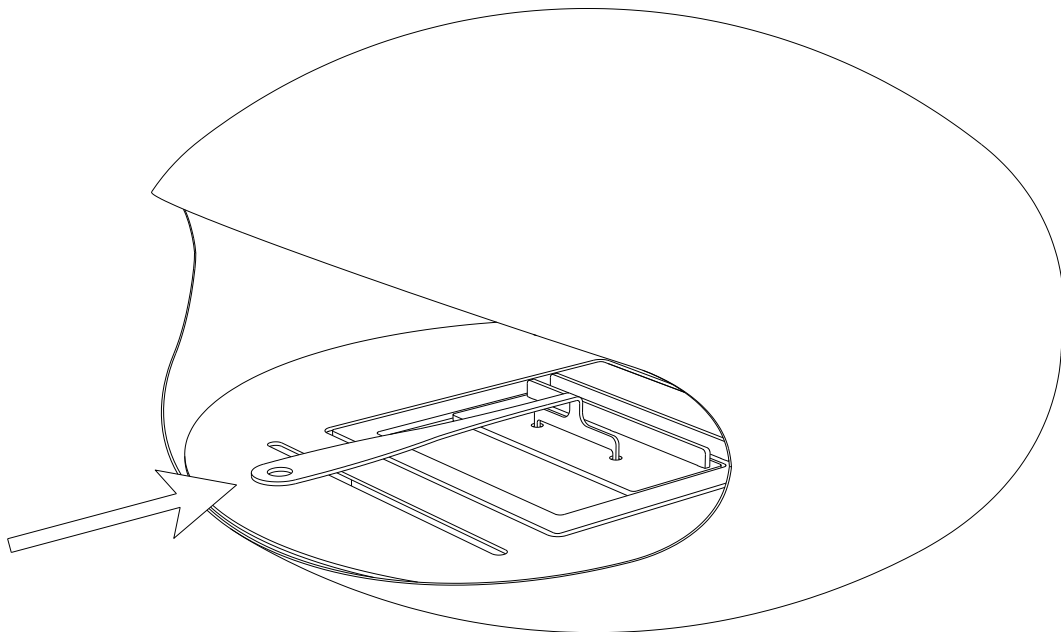

To extinguish the flame, insert the tips of the *Sliding Lid Handle* into the holes of the *Sliding Lid* of the *Combustion Chamber* and slide all the way forward until the flame is extinguished.

TO REFILL THE COMBUSTION CHAMBER

NEVER REFILL OR IGNITE THE COMBUSTION CHAMBER WHEN IT IS IN A HOT STATE.

When refilling the *Combustion Chamber*, simply follow the same procedure indicated in the section headed "OPERATING THE COCOON BURNER" taking note of the CAUTION and WARNING on this page. **It is critical to the proper functioning of the Combustion Chamber that you do not overfill the fuel tank as indicated before.**

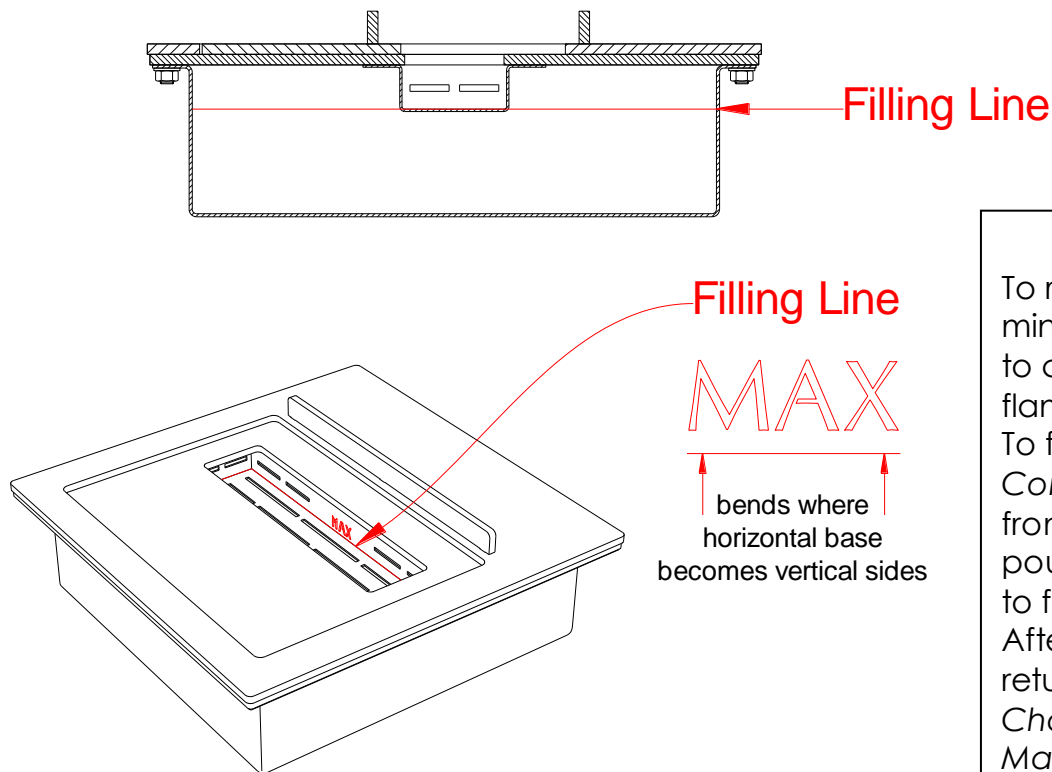

CAUTION

To refill wait at least 45 minutes for the burner to cool down after the flame has turned off. To fill remove *Combustion Chamber* from *Main Body* and pour fuel inside. Fill up to fill line of 1,5 liters. After filling is done return the *Combustion Chamber* inside the *Main Body*.

Maintenance & Periodic Servicing:

1. Periodic cleaning of unvented decorative appliance combustion surfaces is recommended as per section called TROUBLESHOOTING & OPERATIONAL TIPS.
2. Checking operation of *Sliding Lid* shutoff device should be done regularly.

Make sure the fireplace has cooled completely before cleaning.

To clean dust wipe with a dry cloth or sponge.

To clean stainless steel parts use alcohol or Acetone.

Make sure the *Sliding Lid* from the *Combustion Chamber* slides correctly, smoothly, and fully every time before igniting the *Combustion Chamber*.

WARNING

1. Risk of Explosion:
 - i) Never use any fuel other than the fuel specifically intended for use in the unvented decorative appliance. Never use gasoline.
 - ii) Never refill unvented decorative appliance fuel reservoir when unvented decorative appliance is operating or still hot.
 - iii) Never use unvented decorative appliance where flammable vapours or gas may be present.
 - iv) Never store or transport the fuel in other than a metal or plastic container that is:
 - A) Acceptable for use with the specific fuel;
 - B) Non-red in colour;
 - C) Is in the original container for the (specific alcohol) Fuel.
2. Never store fuel in the living space/same location as the appliance.
3. Due to high surface temperatures, keep children, clothing and furniture away.
4. Risk of Indoor Air Pollution – Use unvented decorative appliance only in well-ventilated areas and with door of adjacent room open. **Do not obstruct air flow to the fuel holder box by piling logs over the fuel holding box, but only around it and do not obstruct the fuel holder box in any other way or with any other material.** People with breathing problems should consult a physician before using the unvented decorative appliance.
5. Do not use unvented decorative appliance to heat or boil water or use a cooking appliance.
6. **Do not use in a room with Oxygen tanks in use.**



Patent Pending

info@cocoonfires.com
www.cocoonfires.com ®



info@cocoonfires.com
www.cocoonfires.com